

# REPAIR OF SHEET METAL ROOFS IN CYCLONIC AREAS

PRODUCED IN PARTNERSHIP WITH TIMBER QUEENSLAND





# 1. INTRODUCTION

This guideline has been developed to assist builders and building certifiers in the repair or reconstruction of damaged sheet metal roofs in cyclone areas. Information is also provided on building and planning approvals when repairing or rebuilding a home.

This guideline does not replace or override any legislative requirements, and it should be read in conjunction with current laws, codes and standards, including:

- National Construction Code
- Australian Standard (AS) 1684.3 current
- *Building Act 1975* and Building Regulation 2021
- *Planning Act 2016* and Sustainable Planning Regulation 2009

## 1.1 Building approvals

### What is a building approval?

Under the *Building Act 1975*, all new building work in Queensland is assessable and requires an approval, unless it is prescribed as self-assessable or is exempt under the Building Regulation 2021 (refer Schedules 1 and 2).

Building approvals help ensure buildings are constructed to standards that address health and amenity, safety and sustainability. Buildings are assessed against the Building Code of Australia and the Queensland Development Code.

Self-assessable building work does not require an approval, but must still comply with all relevant building codes and standards.

Exempt building work requires no building approvals and does not need to meet building regulations.

### Is a building approval required to repair a home?

A building approval is not generally required where the work involves repairing or replacing fixtures, kitchen cupboards, vanity units, floor coverings or repairing or replacing internal wall linings.

Undertaking more extensive repair work affecting the structural components of a building will require a building approval.

Exemptions may apply for minor structural work where the work does not affect more than 20 per cent of the building's structural like-for-like parts, for example, replacing a like-for-like roof beam supporting up to 5m<sup>2</sup> of roof area.

Any repair work is generally required to meet current building codes. This may assist to improve a building's ability to withstand future wind events.

When undertaking repairs, it may be worthwhile giving consideration to upgrading other aspects of the home to help improve its resilience to future wind events. For example, if only the roof sheeting needs to be repaired, consideration could also be given to upgrading the tie down connections for the whole roof structure including checking the adequacy of roof battens. A building certifier can provide advice on these issues.

If you are unsure what standards any repair work needs to meet, you should contact a building certifier for advice.

### Is a building approval required to substantially rebuild a home?

Yes. A building certifier will need to confirm the proposed building work complies with the relevant building codes before any construction begins.

### Special circumstances

The *Planning Act 2016* provides an exemption for building work undertaken in emergency situations. This exemption authorises building work to be undertaken without the usual approvals in circumstances related to an emergency endangering life or health, or the structural safety of a building.

In those circumstances, the building work may be undertaken without a building approval, however the Local Government must be advised in writing as soon as practicable after starting the work.

## 1.2 Planning approvals

### What is a planning approval?

Generally, a planning approval determines what uses and activities can occur on the land to minimise any potential impacts on surrounding areas. In the majority of cases planning approvals are granted by Local Government.

If a planning approval is required for a development, then a building approval cannot be given by a building certifier until the planning approval is obtained and any conditions of approval are complied with.

### Is a planning approval required to repair a home?

If repairing a house to its original pre-damaged condition—no planning application is generally required, however this should be confirmed with the Local Government. Is planning approval required to relocate a home on a site?

For lots 450 square metres or more or with a width greater than 15 metres, a planning approval is generally not required except where the dwelling is:

- proposed to be located in an area affected by mining
- within an urban stormwater flow path
- within a character zone or where the dwelling is a listed character building.

This should however, be confirmed with your Local Government. Character areas are areas identified by a Local Government, which through a combination of factors including building style and physical environment, are protected.

You should also determine if any boundary setback relaxations are required if it is proposed to place the building close to the boundaries.

For lots less than 450 square metres, consult directly with the relevant Local Government, as regulations for small lots vary between each Local Government area.

## Is Local Government planning approval required to completely rebuild a home?

Provided a building is being replaced as it was, on a like for like basis, no planning approval is generally required, but you should confirm this with the Local Government. However, if the location, size, materials (if in a character/heritage overlay in the planning scheme) or use of the building is being changed, review your Local Government's planning scheme to confirm whether these works are assessable and trigger the requirement for a planning approval. Many Local Governments include siting and boundary clearance requirements in their planning schemes as an alternative to the provisions in the Queensland Development Code.

## I am unable to get approved plans. How do I ensure I am replacing like-for-like?

In the absence of approved plans, the use of evidence such as photographs, aerial photography, sewer and drainage plans may be combined to establish evidence of like-for-like replacement. Additional guidance could be provided by consulting with a building certifier who has appropriate knowledge or the Local Government, prior to undertaking any building work.

## 1.3 Demolishing a building

What approvals are required to demolish a home after damage has made it structurally unsafe?

Where a property is outside a character area and the home is structurally unsound, the building can generally be demolished without obtaining planning approval.

However, building approval may be required for demolition of a building.

Character areas are areas identified by a Local Government, which through a combination of factors including building style and physical environment, are protected.

If a house is located in a character area or where you have a State or locally listed character place, a planning approval is likely to be required. In this instance, contact the Local Government.

## Can the Local Government force a property owner to demolish their home?

Local Government has powers to require owners to demolish dangerous or dilapidated buildings and structures. As a last resort, Local Government may take action to demolish buildings if owners refuse to comply with an enforcement notice.

Owners may appeal enforcement notices to the Building and Development Dispute Resolution Committees.

Building and Development Dispute Resolution Committees

Telephone: +61 7 3237 0403, Fax: +61 7 3237 1248

Email: [Registrar@dip.qld.gov.au](mailto:Registrar@dip.qld.gov.au)



## 2. BACKGROUND

The following simplified details are provided to assist builders and building certifiers

in the repair or reconstruction of damaged sheet metal roofs in cyclonic areas. They do not apply to roofs covered with other materials, such as tiles.

The details cover fixings ranging from roof battens to top plates. Specific details of roof sheeting fixings are given in accordance with the sheeting manufacturers specifications for wind classification C2 (maximum design gust wind speed 61m/s = old 'W50').

Please note, this guideline must not be used on sites where the wind classification may exceed C2, for example, elevated or exposed sites (i.e. where the house has a view). If in doubt about your site classification, seek advice from a registered professional engineer or other competent person.

In repairing or rebuilding roofs to the standards outlined in this guideline, users should be aware that the whole building or structure will not necessarily have been brought up to a standard that complies with current building laws.

Any repair work is generally required to meet current building codes, including the National Construction Code and AS 1684, Residential timber-framed construction, Part 3: Cyclonic areas. This guideline does not replace or override any legislative requirements, and it should be read in conjunction with relevant laws, codes and standards.

When undertaking repairs, the builder or building certifier may wish to discuss with the homeowner options for upgrading other aspects of the home to help improve its resilience to future wind events. For example, if only the roof sheeting needs to be repaired, consideration could also be given to upgrading the tie down connections for the whole roof structure.

This guideline aims to provide simplified tie-down details for a limited range of building geometries, types and member spacings. For more detailed tie-down design and information, please refer to AS 1684.



# 3. PROCEDURAL GUIDE

## 3.1 Roof Battens

- (1) From table 1, determine the uplift force on the batten to rafter or truss connection.
- (2) From details sheet 1, determine an appropriate connection with strength equal

## 3.2 Roof Framing and Trusses

- (1) From figure 1 determine the uplift load width (ULW) for the tie-down connection under consideration.
- (2) From table 2, determine the uplift force on the connection under consideration
- (3) From details sheets 2 to 4, determine an appropriate connection with a strength equal to or greater than the uplift force determined from table 2.

**Figure 1—Roof uplift load width (ULW) for wind**

### A. ROOF BEAM CONSTRUCTION

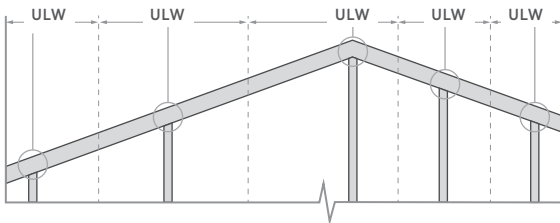

### B. RAFTERED ROOF CONSTRUCTION

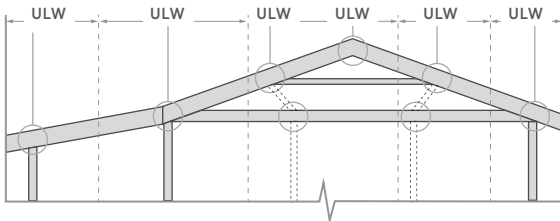

### C. TRUSSED ROOF CONSTRUCTION

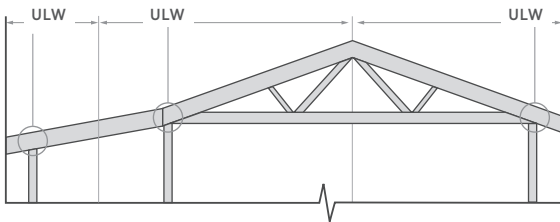

**Table 1—Uplift forces on roof battens**

RAFTER OR TRUSS SPACING (mm)	BATTEN SPACING (mm)	UPLIFT FORCE (kN)	
		NEAR EDGES	GENERAL AREA
900	600	3.0	1.9
	900	4.5	2.8
1200	600	4.0	2.5
	900	5.9	3.8

NOTE. Near edges applies to the batten closest to the ridge, the batten closest to the end of the eaves overhang, and to the batten end connections at the gable or hip.

**Table 2—Uplift forces on roof framing**

UPLIFT LOAD WIDTH (ULW) (mm)	RAFTER OR TRUSS SPACING (mm)	UPLIFT FORCE (kN)
0 to 1500	900	4.4
	1200	5.9
1501 to 3000	900	8.8
	1200	12
3001 to 4500	900	13
	1200	18
45001 to 6000	900	18
	1200	23

NOTE: All timber to be hardwood, cypress or seasoned softwood

## 3.3 Uplift force on studs

Uplift force on studs (refer to sheet 4) at 450mm or 600mm centres will be 50 per cent of the value of the uplift force given for 900mm or 1200mm rafter or truss spacings.

## 4. OTHER IMPORTANT ISSUES

### 4.1 Pre drilling timber

Timber in older homes will be well seasoned and prone to splitting. Splitting will weaken the connection so timber should be predrilled to avoid this from happening.

The pre drilled hole should be no greater than 80% of the diameter of the fastener being used.

### 4.2 Split, decayed or insect damaged timber

If existing timber members are split, damaged by rot or insects the member will be weakened and should be replaced.

### 4.3 Washer sizes

Bolt and coach screw connections will require washers. The following washer sizes are required:

- Where an M10 bolt or coach screw is used— a 38mm X 38mm x2mm washer is needed.
- Where an M12 bolt or coach screw is used— a 50mm X 50mm x3mm washer is needed.
- Where an M16 bolt or coach screw is used— a 65mm X 65mm x5mm washer is needed.

### Detail sheet 1—Roof battens to rafters or trusses

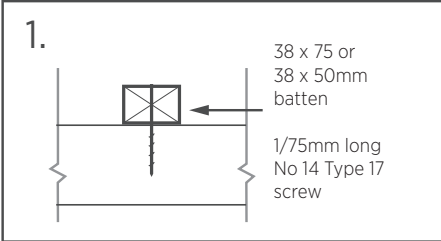
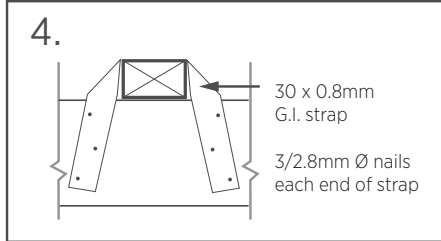
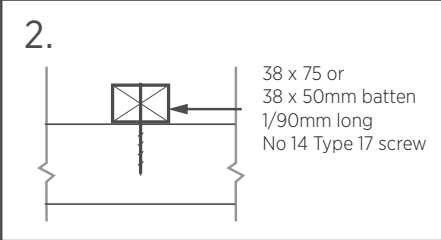
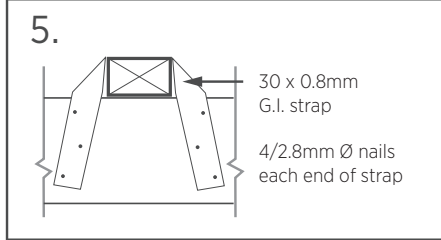
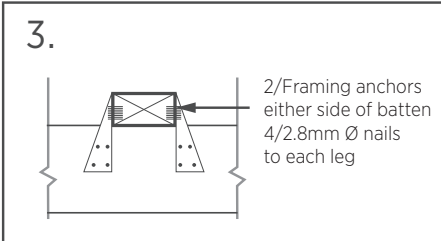
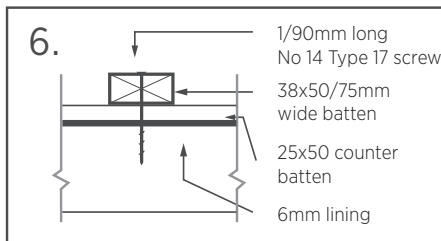
DETAIL	UPLIFT CAPACITY (kN)	DETAIL	UPLIFT CAPACITY (kN)
<p>1.</p>  <p>38 x 75 or 38 x 50mm batten</p> <p>1/75mm long No 14 Type 17 screw</p>	<b>4.5</b>	<p>4.</p>  <p>30 x 0.8mm G.I. strap</p> <p>3/2.8mm Ø nails each end of strap</p>	<b>4.7</b>
<p>2.</p>  <p>38 x 75 or 38 x 50mm batten</p> <p>1/90mm long No 14 Type 17 screw</p>	<b>6.0</b>	<p>5.</p>  <p>30 x 0.8mm G.I. strap</p> <p>4/2.8mm Ø nails each end of strap</p>	<b>5.9</b>
<p>3.</p>  <p>2/Framing anchors either side of batten</p> <p>4/2.8mm Ø nails to each leg</p>	<b>5.9</b>	<p>6.</p>  <p>1/90mm long No 14 Type 17 screw</p> <p>38x50/75mm wide batten</p> <p>25x50 counter batten</p> <p>6mm lining</p>	<b>2.6</b>

Detail sheet 2—Rafters to rafters at ridge, rafter to underpurlins and to ceiling/wall frame

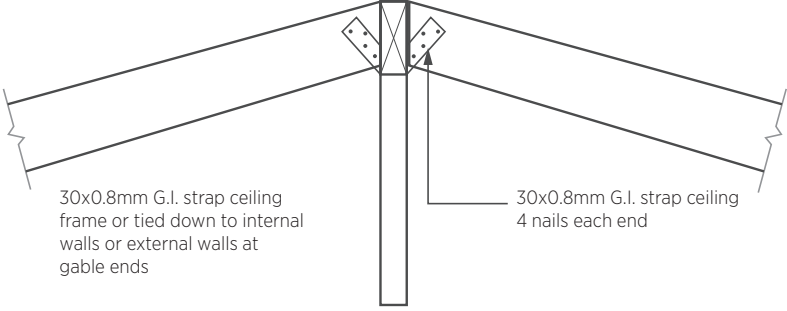
DETAIL	UPLIFT CAPACITY (kN)
<p>8.</p>  <p>30x0.8mm G.I. strap ceiling frame or tied down to internal walls or external walls at gable ends</p> <p>30x0.8mm G.I. strap ceiling 4 nails each end</p>	<p>4.7</p>

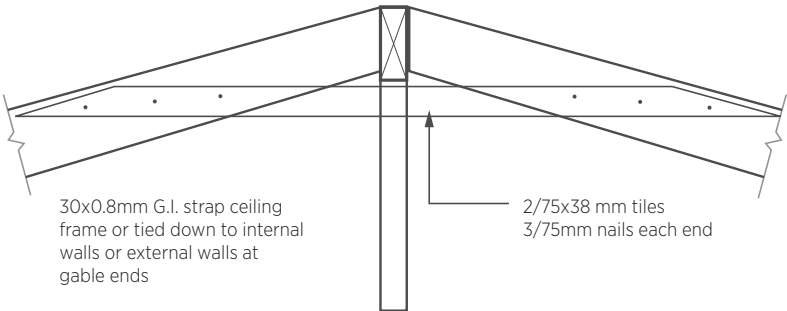
DETAIL	UPLIFT CAPACITY (kN)
<p>9.</p>  <p>30x0.8mm G.I. strap ceiling frame or tied down to internal walls or external walls at gable ends</p> <p>2/75x38 mm tiles 3/75mm nails each end</p>	<p>4.7</p>

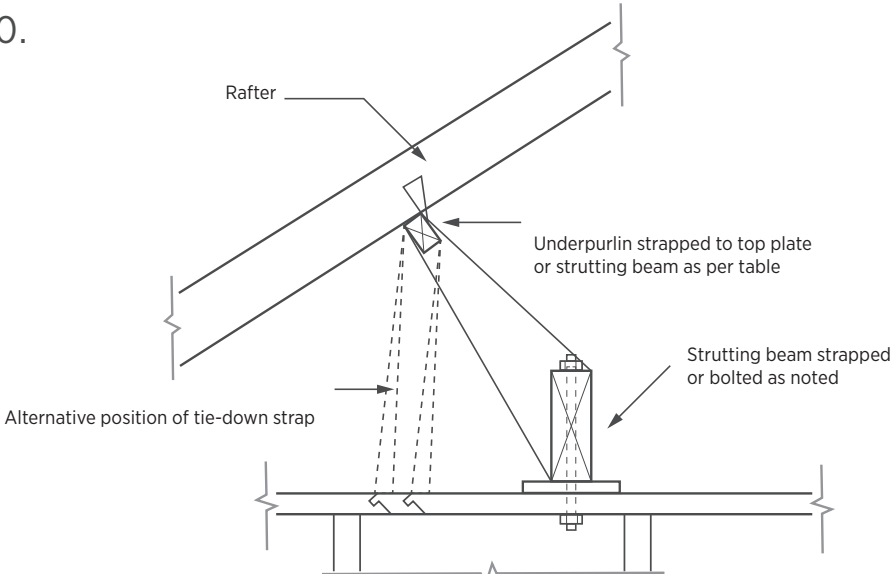
DETAIL	UPLIFT CAPACITY (kN)
<p>10.</p>  <p>Rafter</p> <p>Underpurlin strapped to top plate or strutting beam as per table</p> <p>Strutting beam strapped or bolted as noted</p> <p>Alternative position of tie-down strap</p>	<p>5.9 (13 if underpurlin is tied down to wall studs or floor frame with a looped strap or M10 bolt)</p>

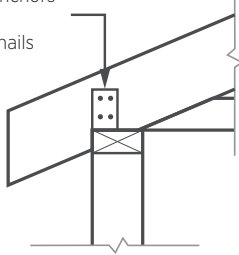
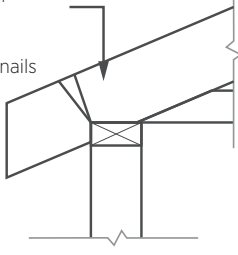
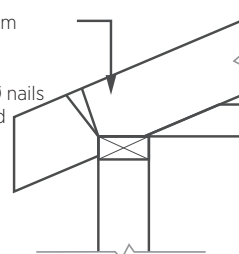
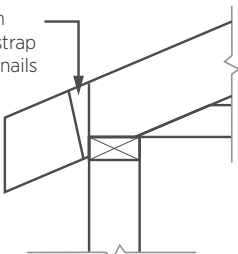
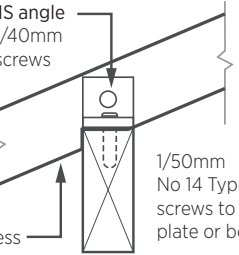
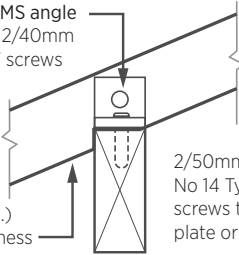

Detail sheet 3—Rafter/trusses to top plate or wall frame

DETAIL	UPLIFT CAPACITY (kN)	DETAIL	UPLIFT CAPACITY (kN)
<p>11.</p> <p>2/Framing anchors 4/2.8mm Ø nails to each end</p> 	<p>5.9</p>	<p>12.</p> <p>1/30x0.8mm G.I. strap 3/2.8mm Ø nails to each end</p> 	<p>4.7</p>
<p>DETAIL</p>	<p>UPLIFT CAPACITY (kN)</p>	<p>DETAIL</p>	<p>UPLIFT CAPACITY (kN)</p>
<p>13.</p> <p>2/30x0.8mm G.I. strap 3/2.8mm Ø nails to each end</p> 	<p>8.4</p>	<p>14.</p> <p>1/30x0.8mm G.I. looped strap 4/2.8mm Ø nails to each end</p> 	<p>13</p>
<p>DETAIL</p>	<p>UPLIFT CAPACITY (kN)</p>	<p>DETAIL</p>	<p>UPLIFT CAPACITY (kN)</p>
<p>15.</p> <p>75x50x5mm MS angle 1/M10 bolt or 2/40mm No 14 Type 17 screws to rafter 35mm (min.) rafter thickness 1/50mm No 14 Type 17 screws to top plate or beam</p> 	<p>4.2</p>	<p>16.</p> <p>75x50x5mm MS angle 1/M10 bolt or 2/40mm No 14 Type 17 screws to rafter 35mm (min.) rafter thickness 2/50mm No 14 Type 17 screws to top plate or beam</p> 	<p>5.1</p>

Detail sheet 4—Top plates to studs and general connections

DETAIL	UPLIFT CAPACITY (kN)	DETAIL	UPLIFT CAPACITY (kN)
<p>17.</p> <p>Screws as per table Recess head if required to ensure minimum penetration 50mm min. penetration into end grain 30mm min. penetration</p>	<p>No 14 Type 17 screw or M10 coach screw</p> <p><b>3.6</b></p>	<p>18.</p> <p>30x0.8mm G.I. strap 4/2.8mm Ø nails each end a</p>	<p><b>5.9</b></p>
<p>19.</p> <p>30x0.8mm G.I. strap 6/2.8mm Ø nails each end a</p>	<p><b>8.4</b></p>	<p>20.</p> <p>Bolts as per table</p>	<p>M10 <b>15</b> M12 <b>20</b> M16 <b>35</b></p>
<p>21.</p> <p>100mm max. Bolts as per table Plate or beam</p>	<p>M10 cup head <b>10</b> M12 cup head <b>12</b> M12 bolt/rod <b>20</b></p>		



**For more information**

Visit [qbcc.qld.gov.au](http://qbcc.qld.gov.au) or call us on 139 333.



Level 1, 30 Boothby Street, Kedron, Queensland 4031  
PO Box 231, Kedron, Queensland 4031  
T: 07 3358 7900  
W: [timberqueensland.com.au](http://timberqueensland.com.au)



GPO Box 5099, Brisbane Qld 4001